

# HD10AMA HD/SD 4-Channel Analog Embedder/Disembedder User Manual

# HD10AMA

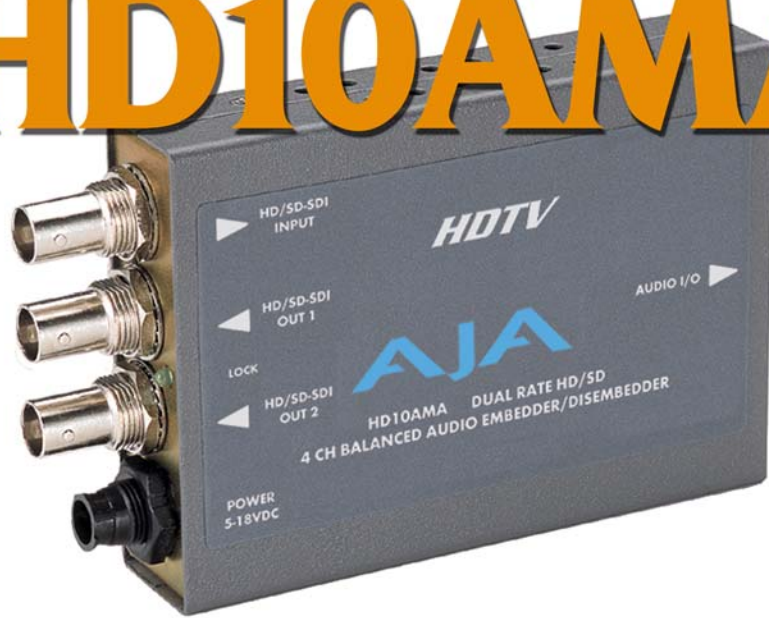

**AJA**  
AJA VIDEO SYSTEMS INC

July 21, 2006 P/N 101659-00

## Trademarks

---

AJA, Io, and Kona are trademarks of AJA Video, Inc. All other trademarks are the property of their respective holders.

## Notice

---

Copyright © 2006 AJA Video, Inc. All rights reserved. All information in this manual is subject to change without notice. No part of the document may be reproduced or transmitted in any form, or by any means, electronic or mechanical, including photocopying or recording, without the express written permission of AJA Inc.

## FCC Emission Information

---

This equipment has been tested and found to comply with the limits for a Class A digital device, pursuant to Part 15 of the FCC Rules. These limits are designed to provide reasonable protection against harmful interference when the equipment is operated in a commercial environment. This equipment generates, uses and can radiate radio frequency energy and, if not installed and used in accordance with the instruction manual, may cause harmful interference to radio communications. Operation of this equipment in a residential area is likely to cause harmful interference in which case the user will be required to correct the interference at his own expense. Changes or modifications not expressly approved by AJA Video can effect emission compliance and could void the user's authority to operate this equipment.

## Contacting Support

---

To contact AJA Video for sales or support, use any of the following methods:

443 Crown Point Circle, Grass Valley, CA. 95945 USA

Telephone: +1.800.251.4224 or +1.530.274.2048

Fax: +1.530.274.9442

Web: <http://www.aja.com>

Support Email: [support@aja.com](mailto:support@aja.com)

Sales Email: [sales@aja.com](mailto:sales@aja.com)

When calling for support, have all information on the product (serial number etc.) at hand prior to calling.

## Limited Warranty

---

AJA Video warrants that this product will be free from defects in materials and workmanship for a period of five years from the date of purchase. If a product proves to be defective during this warranty period, AJA Video, at its option, will either repair the defective product without charge for parts and labor, or will provide a replacement in exchange for the defective product.

In order to obtain service under this warranty, you the Customer, must notify AJA Video of the defect before the expiration of the warranty period and make suitable arrangements for the performance of service. The Customer shall be responsible for packaging and shipping the defective product to a designated service center nominated by AJA Video, with shipping charges prepaid. AJA Video shall pay for the return of the product to the Customer if the shipment is to a location within the country in which the AJA Video service center is located. Customer shall be responsible for paying all shipping charges, insurance, duties, taxes, and any other charges for products returned to any other locations.

This warranty shall not apply to any defect, failure or damage caused by improper use or improper or inadequate maintenance and care. AJA Video shall not be obligated to furnish service under this warranty a) to repair damage resulting from attempts by personnel other than AJA Video representatives to install, repair or service the product, b) to repair damage resulting from improper use or connection to incompatible equipment, c) to repair any damage or malfunction caused by the use of non-AJA Video parts or supplies, or d) to service a product that has been modified or integrated with other products when the effect of such a modification or integration increases the time or difficulty of servicing the product.

THIS WARRANTY IS GIVEN BY AJA VIDEO IN LIEU OF ANY OTHER WARRANTIES, EXPRESS OR IMPLIED. AJA VIDEO AND ITS VENDORS DISCLAIM ANY IMPLIED WARRANTIES OF MERCHANTABILITY OR FITNESS FOR A PARTICULAR PURPOSE. AJA VIDEO'S RESPONSIBILITY TO REPAIR OR REPLACE DEFECTIVE PRODUCTS IS THE WHOLE AND EXCLUSIVE REMEDY PROVIDED TO THE CUSTOMER FOR ANY INDIRECT, SPECIAL, INCIDENTAL OR CONSEQUENTIAL DAMAGES IRRESPECTIVE OF WHETHER AJA VIDEO OR THE VENDOR HAS ADVANCE NOTICE OF THE POSSIBILITY OF SUCH DAMAGES.

## Introduction

The HD10AMA is a dual rate 4 channel analog audio Embedder/Disembedder. The Disembedder is always functional providing 4 outputs. The Embedder is user selectable, on a channel pair basis, to either “pass” input audio or embed input audio from the breakout cable. Analog audio levels are selectable. The HD10AMA automatically detects and configures to the input video standard.

## Features

- Dual rate HD-SDI/SDI Embedder/Disembedder
- 4 Channel Balanced Analog Audio I/O
- Supplied XLR breakout cable
- HD-SDI/SDI input, 2 HD-SDI/SDI outputs
- Dipswitch configuration
- 5-18VDC Power

## Block Diagram

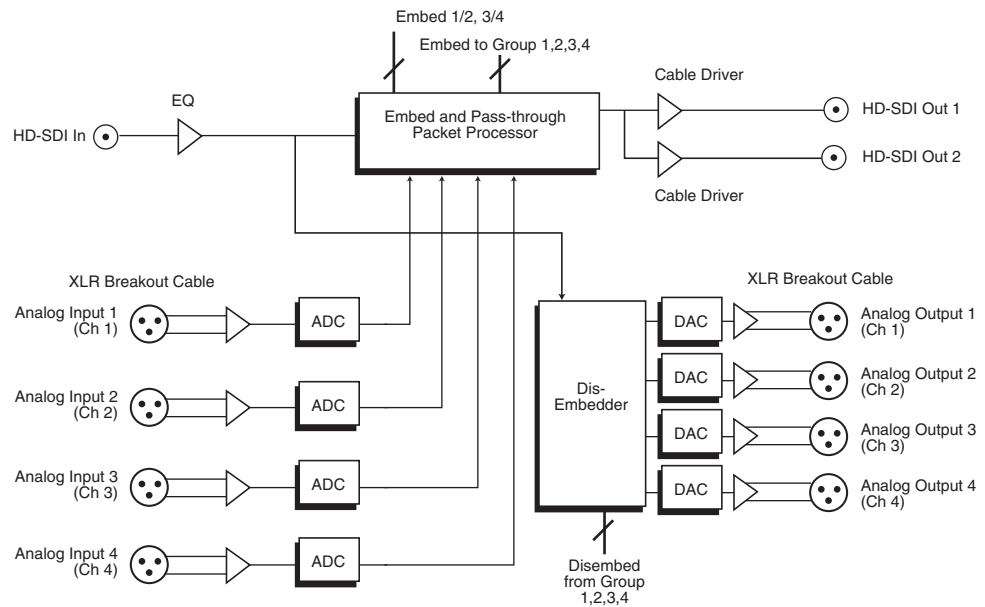

***HD10AMA, Block Diagram***

## I/O Connections

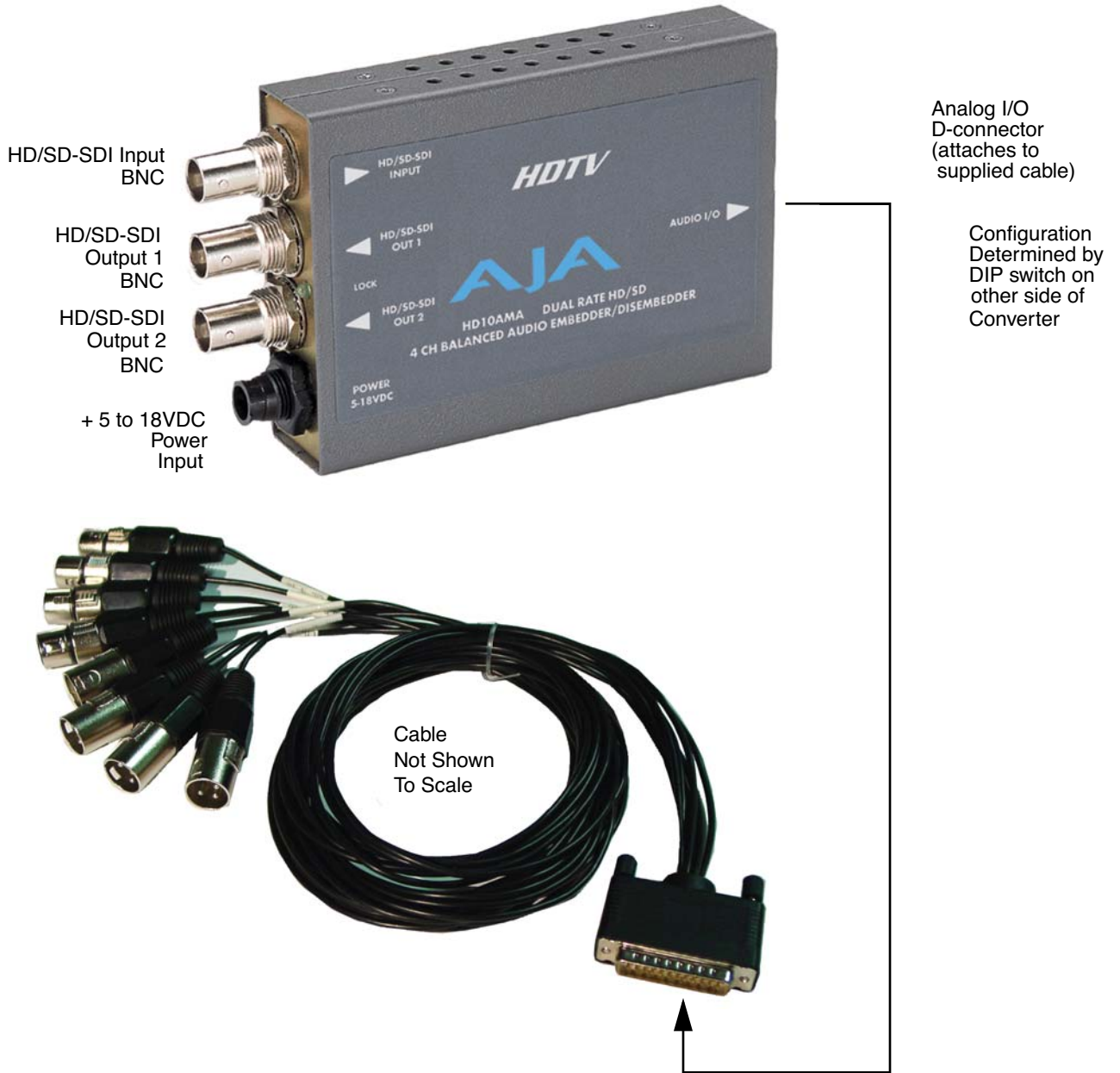

*HD10AMA and Cable, Side View*

## User Controls

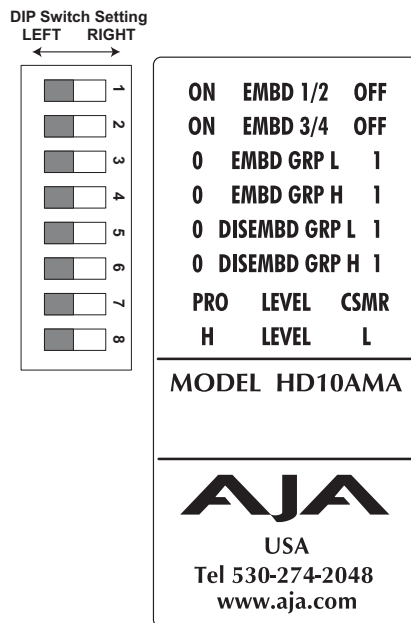

The user interface for the HD10AMA is an 8-switch DIP accessible through a cut-out in the bottom of the unit. Use the DIP switches to configure how the Analog embedding and disembedding functions. There is also a jumper on the internal circuit board, accessible by removing the outer shell case of the HD10AMA. Located by the DIP switch, this jumper is used in conjunction with the DIP switches 1 and 2 to select certain functions. The factory default setting for the AUX jumper is “OPEN”. To remove the case shell, simply remove the four phillips screws that fasten the back half of the case shell (the half having the DIP switch access hole).

**Note:** The combination of the AUX jumper setting and the DIP switch settings determines the overall operation of the HD10AMA.

The exact function of each DIP switch and what it controls is described on the following pages.

### DIP Switch Settings

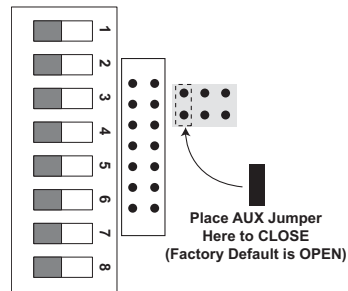

### AUX Jumper (Accessed On Circuit Board Inside The HD10AMA Case)

#### Switch 1 (EMBD 1/2)—Controls Audio Embedding for Channels 1/2

LEFT	RIGHT
Overwrite or embed new channel 1/2 packets	If AUX Jumper is OPEN: Pass any channel 1/2 packets on input SDI. If AUX Jumper is CLOSED: Delete all channel 1/2 packets from input SDI.

#### Switch 2 (EMBD 3/4)—Controls Audio Embedding for Channels 3/4

LEFT	RIGHT
Overwrite or embed new channel 3/4 packets	If AUX Jumper is OPEN: Pass any channel 3/4 packets on input SDI. If AUX Jumper is CLOSED: Delete all channel 3/4 packets from input SDI.

## Switches 3 and 4 (EMBD GRP L) and (EMBD GRP H)— Channel Mapping For Embedded Groups

The following tables show how combinations of setting these two switches affects channel mapping.

Switch 3: EMBD GRP L Left (0), Switch 4: EMBD GRP H Left (0)

Audio Input Channel	SDI Embedded Output Group	SDI Embedded Output Channel
1 →	1	1
2 →	1	2
3 →	1	3
4 →	1	4

Switch 3: EMBD GRP L Right (1), Switch 4: EMBD GRP H Left (0)

Audio Input Channel	SDI Embedded Output Group	SDI Embedded Output Channel
1 →	2	5
2 →	2	6
3 →	2	7
4 →	2	8

Switch 3: EMBD GRP L Left (0), Switch 4: EMBD GRP H Right (1)

Audio Input Channel	SDI Embedded Output Group	SDI Embedded Output Channel
1 →	3	9
2 →	3	10
3 →	3	11
4 →	3	12

Switch 3: EMBD GRP L Right (1), Switch 4: EMBD GRP H Right (1)

Audio Input Channel	SDI Embedded Output Group	SDI Embedded Output Channel
1 →	4	13
2 →	4	14
3 →	4	15
4 →	4	16

## Switches 5 and 6 (DISEMBD GRP L) and (DISEMBD GRP H)— Channel Mapping For Disembedding Groups

The following tables show how combinations of setting these two switches affects channel mapping.

Switch 5: DISEMBD GRP L Left (0), Switch 6: DISEMBD GRP H Left (0)

SDI Embedded Input Group	SDI Embedded Input Channel	Audio Output Channel
1	1 →	1
1	2 →	2
1	3 →	3
1	4 →	4

Switch 5: DISEMBD GRP L Right (1), Switch 6: DISEMBD GRP H Left (0)

SDI Embedded Input Group	SDI Embedded Input Channel	Audio Output Channel
2	5 →	1
2	6 →	2
2	7 →	3
2	8 →	4

Switch 5: DISEMBD GRP L Left (0), Switch 6: DISEMBD GRP H Right (1)

SDI Embedded Input Group	SDI Embedded Input Channel	Audio Output Channel
3	9 →	1
3	10 →	2
3	11 →	3
3	12 →	4

Switch 5: DISEMBD GRP L Right (1), Switch 6: DISEMBD GRP H Right (1)

SDI Embedded Input Group	SDI Embedded Input Channel	Audio Output Channel
4	13 →	1
4	14 →	2
4	15 →	3
4	16 →	4

### Switch 7 (LEVEL)—Control Whether Audio Levels are Professional Or Consumer. Affects all 4 Inputs and Outputs

LEFT	RIGHT
Professional Levels (See I/O Level Selection Matrix Table)	Consumer Levels (See I/O Level Selection Matrix Table)

**Note:** Professional audio equipment has much higher levels than consumer equipment: a 0 VU reading corresponds to +4 dBu. Connecting a professional +4 dBu device to a consumer audio input (-7 to -8 dBu) may produce dangerous overloading, whereas the output of a consumer device probably does not have sufficient power to drive a professional audio input. With consumer and semi-professional audio equipment, a VU reading of 0 dB is typically referenced to -10 dBV, which is equivalent to -7.78 dBu.

### Switch 8 (LEVEL)—Control Whether Audio Levels are High or Low. Affects all 4 Inputs and Outputs

LEFT	RIGHT
High Levels (See I/O Level Selection Matrix Table)	Low Levels (See I/O Level Selection Matrix Table)

### Output Level Selection Matrix For Switches 7 and 8

The following table shows the combinations of DIP switch settings required to configure the audio output levels shown.

In/Out Level Range	Nominal (-20dBFS)	Full Scale (0dBFS)	DIP Switch #7	DIP Switch #8
Professional US	+4dBu	+24dBu	LEFT	LEFT
Professional European	-2dBu	+18dBu	LEFT	RIGHT
Consumer High	-8dBu	+12dBu	RIGHT	LEFT
Consumer Low	-14dBu	+6dBu	RIGHT	RIGHT

## Installation

Typically, HD10AMA installation consists of the following:

1. disconnect +5VDC from the converter
2. configure the DIP switch for the desired equipment configuration and video formats
3. connect video equipment to the converter BNCs
4. apply +5VDC power to the converter (AJA power supply model DWP)

## Specifications

Item	Specification
Formats	HD SMPTE 292/296M SD SMPTE 259M (Automatic Configuration)
Video Input	HD-SDI or SDI BNC
Video Outputs	HD-SDI or SDI, 2x BNC
Audio Inputs	4 x Balanced Analog Audio, XLR
Audio Outputs	4 x Balanced Analog Audio, XLR
Audio Levels (Full Scale Digital)	See <i>Output Level Selection Matrix</i> presented earlier
Audio Converters	24 bit
Embedded Audio	SMPTE 272M (SD): 20-bit, 48KHz synchronous SMPTE 299M (HD): 24 bit, 48KHz synchronous
Video Processing Delay	HD Mode: 7 $\mu$ S SD Mode: 19 $\mu$ S
Audio Processing Delay	Disembed Delay: 920 uS Embed Delay: 1200uS
User Controls	External Dipswitch: Embedder on/off, Ch pairs 1/2 - 3/4 Input group select, 1-4 Output Group Select, 1-4 Audio Level: Pro/Consumer, High/Low
Size	5.8" x 3.1" x 1 (147 x 79 x 25mm)
Power	5-18V, 5 watts. Requires power supply.

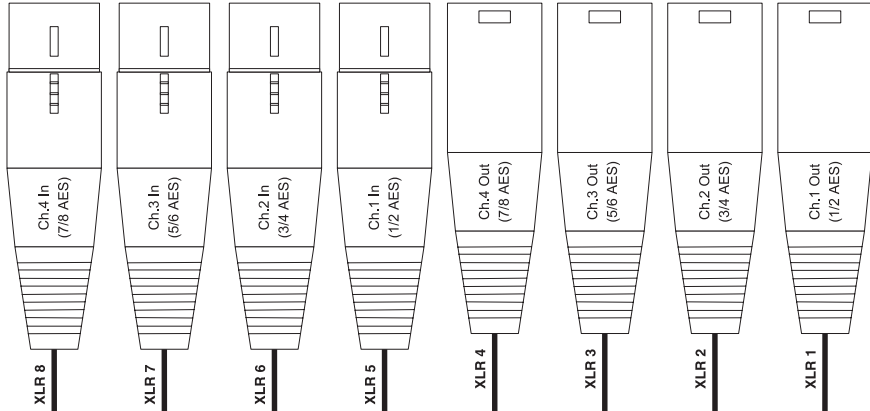
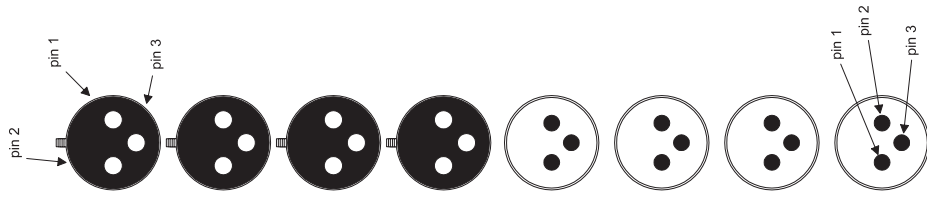

End View:

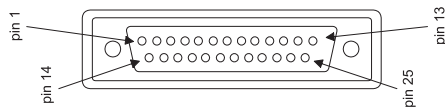

DB25 Connector Pin-out Table

Pin	Function	Pin, -connector-
1	In4 +	2, XLR 8
2	In4 GND	1, XLR 8
3	In3 +	3, XLR 7
4	In3 -	2, XLR 7
5	In2 GND	1, XLR 6
6	In1 +	3, XLR 5
7	In1 -	2, XLR 4
8	Out4 GND	1, XLR 4
9	Out4 +	3, XLR 3
10	Out3 +	2, XLR 2
11	Out3 GND	1, XLR 2
12	Out1 -	3, XLR 1
13	NC	NC
14	In4 +	3, XLR 8
15	In3 +	2, XLR 7
16	In3 GND	1, XLR 7
17	In2 +	3, XLR 6
18	In1 +	2, XLR 5
19	In1 GND	1, XLR 5
20	Out4 +	3, XLR 4
21	Out3 +	2, XLR 3
22	Out3 GND	1, XLR 3
23	Out2 +	3, XLR 2
24	Out2 -	2, XLR 2
25	Out1 GND	1, XLR 1

4 Channel Audio I/O Breakout Cable